

HCD - HIGH CAPACITY DRUM LOUVER

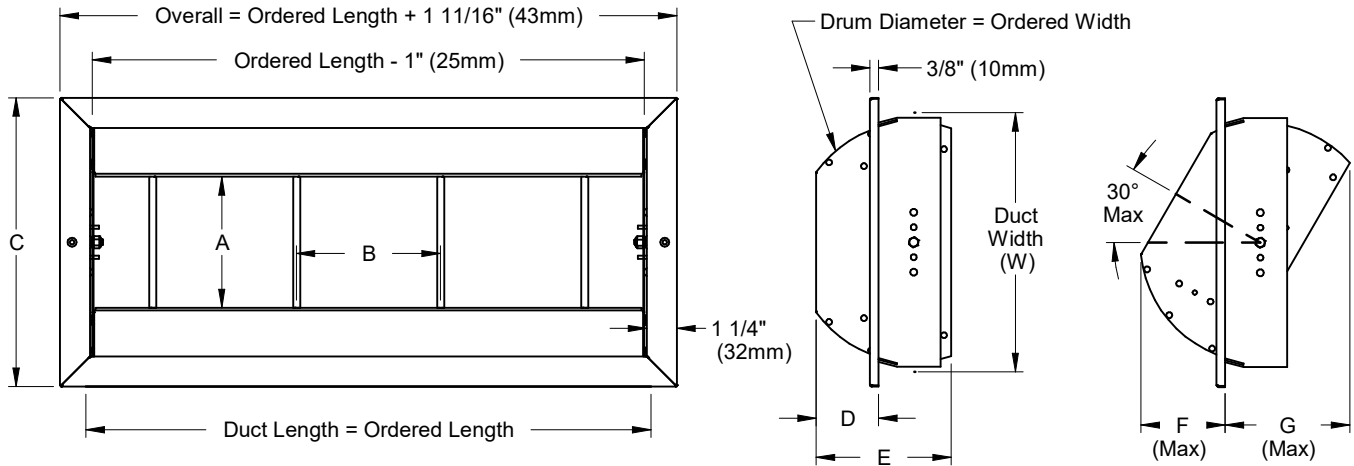

AVAILABLE SIZES:

Ordered Width	Duct Width (W)	A	B	ST Material					AL Material				
				C	D	E	F	G	C	D	E	F	G
4	4-3/4" (121mm)	1-15/16" (49mm)	3" (76mm)	6-5/16" (160mm)	7/8" (22mm)	3-3/8" (86mm)	1-1/4" (32mm)	2-7/8" (73mm)	7" (178mm)	25/32" (20mm)	3-25/32" (96mm)	1-1/8" (29mm)	3" (76mm)
6	6-3/4" (171mm)	3-1/8" (79mm)		8-5/16" (211mm)	1-11/16" (43mm)	3-3/8" (86mm)	2-1/4" (57mm)	3" (76mm)	9" (229mm)	1-19/32" (40mm)	4-19/32" (117mm)	2-1/8" (54mm)	3-3/32" (79mm)
8	8-1/2" (216mm)	4-9/32" (109mm)		10-1/16" (256mm)	1-27/32" (47mm)	4-1/2" (114mm)	2-19/32" (66mm)	4-3/8" (111mm)	10-3/4" (273mm)	1-3/4" (44mm)	4-3/4" (121mm)	2-15/32" (63mm)	4-1/2" (114mm)
10	10-1/2" (267mm)	5-7/16" (138mm)	6" (152mm)	12-1/16" (306mm)	2-5/8" (67mm)	5-5/8" (143mm)	3-1/2" (89mm)	5-3/16" (132mm)	12-3/4" (324mm)	2-1/2" (64mm)	5-5/8" (143mm)	3-13/32" (87mm)	5-5/16" (135mm)
12	12-1/2" (318mm)	6-5/8" (168mm)		14-1/16" (357mm)	3-1/4" (83mm)	6-3/4" (171mm)	4-3/8" (111mm)	6-1/8" (156mm)	14-3/4" (375mm)	3-5/32" (80mm)	6-3/4" (171mm)	4-1/4" (108mm)	6-7/32" (158mm)
15	15-1/2" (394mm)	8-3/8" (213mm)		17-1/16" (433mm)	4-1/4" (108mm)	8-7/16" (214mm)	5-5/8" (143mm)	7-7/16" (189mm)	17-3/4" (451mm)	4-5/32" (106mm)	8-7/16" (214mm)	5-17/32" (140mm)	7-17/32" (191mm)

MATERIAL TYPE:

- ST Steel frame and drum interior, aluminum blades and drum exterior
- AL Aluminum frame and drum

BLADE TYPE:

- 1B Single Blade
- 2B Split Blade

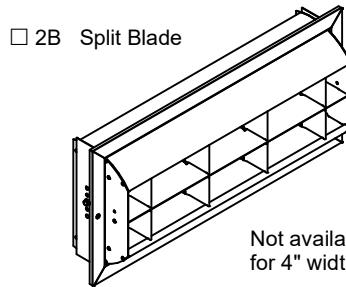
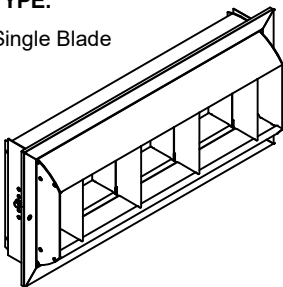

Not available for 4" width

NOTES:

- Available in lengths from 9" (229mm) to 60" (1524mm) for 4", 6", and 8" ordered widths.
- Available in lengths from 18" (457mm) to 72" (1829mm) for 10", 12", and 15" ordered widths.
- Lengths available in 1" (25mm) increments.
- The drum can be rotated to 30° in either direction.
- Detents on the frame hold the drum in the desired position.
- Factory tolerance: ± 1/32" (1mm)

ALL METRIC DIMENSIONS () ARE CONVERTED FROM IMPERIAL AND ROUNDED TO THE NEAREST MILLIMETER.

PROJECT:		 HCD HIGH CAPACITY DRUM LOUVER
ENGINEER:		
CUSTOMER:		
SUBMITTAL DATE:		
SPEC. SYMBOL:		271262
		2025/09/26

HCD - HIGH CAPACITY DRUM LOUVER

OPTIONAL SPIRAL DUCT FRAME:

- SDFG Spiral Duct Frame - Galvanized Steel
- SDFA Spiral Duct Frame - Aluminum (available with aluminum drum only)

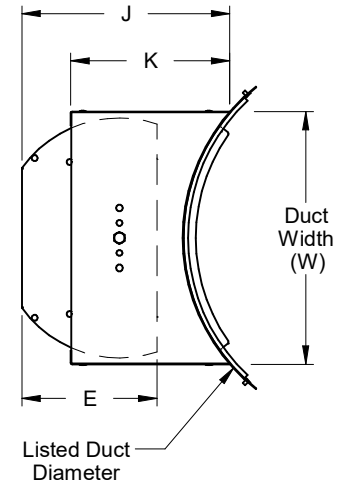
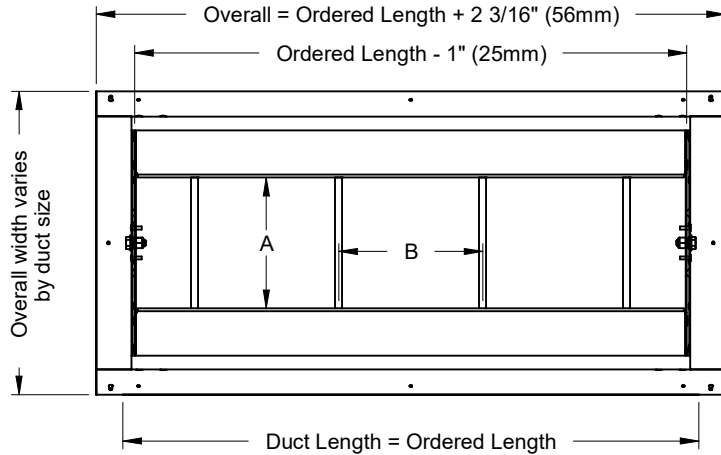

AVAILABLE SIZES:

Ordered Length *	Ordered Width	Duct Width (W)	A	B	E	F	J	K
9" to 48"	4	4-1/2" (114mm)	1-15/16" (49mm)	3" (76mm)	3-3/8" (86mm)	1" (25mm)	3-7/8" (98mm)	3-1/4" (83mm)
	6	6-1/2" (165mm)	3-1/8" (79mm)		3-3/8" (86mm)	1-1/2" (38mm)	5-5/8" (143mm)	4-5/8" (117mm)
	8	8-1/2" (216mm)	4-9/32" (109mm)		4-1/2" (114mm)	2-1/4" (57mm)	6-25/32" (172mm)	5-1/4" (133mm)
18" to 48"	10	10-1/2" (267mm)	5-7/16" (138mm)	6" (152mm)	5-5/8" (143mm)	2-15/16" (75mm)	8-11/16" (221mm)	6-5/8" (168mm)
	12	12-1/2" (318mm)	6-5/8" (168mm)		6-3/4" (171mm)	3-15/16" (100mm)	9-1/2" (241mm)	
	15	15-1/2" (394mm)	8-3/8" (213mm)		8-7/16" (214mm)	5-7/16" (138mm)	10-11/16" (271mm)	

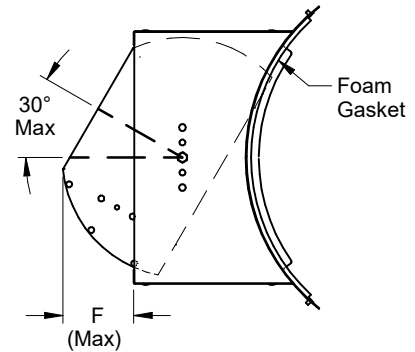

* Lengths available in 1" increments

AVAILABLE DUCT DIAMETERS FOR SPIRAL DUCT FRAME:

Ordered Length	Ordered Width	Spiral Duct Diameter																	
		10	12	14	16	18	20	22	24	26	28	30	32	34	36	38	40	42	48
9" to 48"	4	•	•	•	•	•	•	•	•	•	•	•	•	•	•	•	•		
	6	•	•	•	•	•	•	•	•	•	•	•	•	•	•	•	•		
	8		•	•	•	•	•	•	•	•	•	•	•	•	•	•	•		
18" to 48"	10			•	•	•	•	•	•	•	•	•	•	•	•	•	•		
	12				•	•	•	•	•	•	•	•	•	•	•	•	•	•	
	15					•	•	•	•	•	•	•	•	•	•	•	•	•	•

ALL METRIC DIMENSIONS () ARE CONVERTED FROM IMPERIAL AND ROUNDED TO THE NEAREST MILLIMETER.

PROJECT:		PRICE
ENGINEER:		
CUSTOMER:		<i>MS</i>
SUBMITTAL DATE:		271262
SPEC. SYMBOL:		2025/09/26

HCD
HIGH CAPACITY
DRUM LOUVER

HCD - HIGH CAPACITY DRUM LOUVER

DAMPERS:

VCS3 Opposed Blade Damper (Steel)

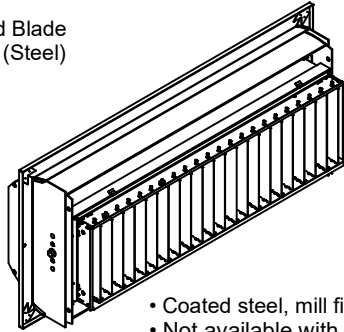
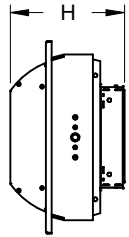

- Coated steel, mill finish
- Not available with 4" width when SDFG or SDFA frame is selected

VCS5 Heavy Duty Opposed Blade Damper (Steel)

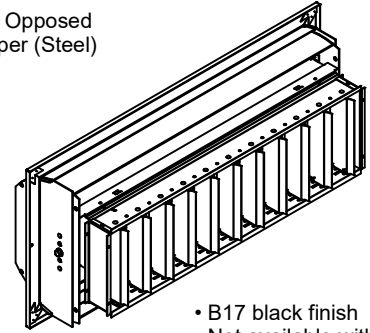
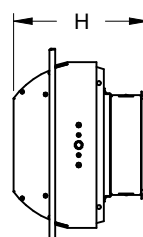

- B17 black finish
- Not available with 4" width

- VCS3 and VCS5 dampers will be provided up to maximum lengths of 24" (610mm) and 36" (914mm) respectively.
- Dampers on longer HCD units will be supplied in multiple sections.

DAMPER SIZE TO ORDER FOR FIELD INSTALLATION*:

Ordered HCD Width	Ordered VCS3 Width	Ordered VCS5 Width	Ordered Damper Length	H	
				VCS3	VCS5
4	3" (76mm)	N/A	Ordered HCD Length - 1"	4-15/16" (125mm)	N/A
6	4" (102mm)	4" (102mm)		4-15/16" (125mm)	6-7/16" (164mm)
8	6" (152mm)	6" (152mm)		6-1/16" (154mm)	7-9/16" (192mm)
10	7" (178mm)	7" (178mm)		7-3/16" (183mm)	8-11/16" (221mm)
12	8-1/2" (216mm)	8" (203mm)	Ordered HCD Length - 2"	7-3/16" (183mm)	8-11/16" (221mm)
15	10" (254mm)	10" (254mm)		8-7/16" (214mm)	8-11/16" (221mm)

* Refer to this table when ordering dampers separately for pre-existing HCD units.

ACCESSORIES:

POB Pole Operator Bracket (available up to 48" ordered length)

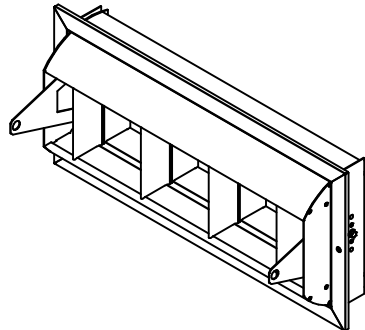
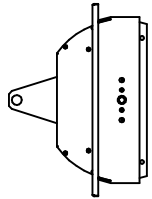

FINISH:

• Drum & Standard Frame:

Standard Finish:
 B12 Standard White

Optional Finishes Available:

- Optional colors
- Custom colors
- See finishes brochure for additional information.
- Contact your PRICE representative for leadtimes and pricing.

• Optional SDFG & SDFA Frame:
• Supplied with Mill finish (unpainted)



Scan for link to additional product information.

ALL METRIC DIMENSIONS () ARE CONVERTED FROM IMPERIAL AND ROUNDED TO THE NEAREST MILLIMETER.

PROJECT:		PRICE	HCD HIGH CAPACITY DRUM LOUVER
ENGINEER:			
CUSTOMER:		271262	
SUBMITTAL DATE:	SPEC. SYMBOL:	2025/09/26	