

STANDARD CONSTRUCTION

CONSTRUCTION

- ALL WELDED

FRAME

- 4.00in x .081in [102mm x 2.1mm] EXTRUDED ALUMINUM (6063-T5) CHANNEL FRAME

BLADES

- Z STYLE BLADES, .081in[2.1mm] EXTRUDED ALUMINUM (6063-T5) 39° BLADE ANGLE, 4.00in[102mm] BLADE SPACING

FINISH

- MILL

MINIMUM SECTION SIZE

- 9.00in W x 9.50in H [229mm x 241mm]

MAXIMUM SECTION SIZE

- ONE PIECE CONSTRUCTION 72in W x 120in H [1829mm x 3048mm] OR 120in W x 72in H [3048mm x 1829mm]
- LARGER LOUVERS WILL REQUIRE FIELD ASSEMBLY OF MULTIPLE SECTIONS AND MAY REQUIRE ADDITIONAL STRUCTURAL SUPPORT BY OTHERS.
- INSTALLATION HARDWARE & STRUCTURAL REINFORCING MEMBERS ARE NOT PROVIDED BY PRICE UNLESS OTHERWISE INDICATED.



Price Industries certifies that the ZE439 shown herein is licensed to bear the AMCA Seal. The ratings shown are based on tests and procedures performed in accordance with AMCA Publication 511 and comply with the requirements of the AMCA Certified Ratings Program. The AMCA Certified Seal applies to air performance ratings.



SIZING NOMINAL ACTUAL

FRAME CHANNEL FLANGED

FINISHES

- MILL PRIME COAT
- BAKED ENAMEL [1]
- 70% PVDF [1]
- 70% PVDF WITH CLEAR TOP COAT [1]
- CLEAR ANODIZED COLOUR ANODIZED [1]

ACCESSORIES

- BIRD SCREEN BIRD SCREEN WITH FRAME
- INSECT SCREEN
- EXTENDED SILL (LOOSE)
- BLANK-OFF PANELS
- INSULATED NON-INSULATED

[1] REFER TO PRICE COLOUR GUIDES FOR A LIST OF AVAILABLE STANDARD COLOURS: [PAINT & ANODIZED](#)
CONSULT PRICE LOUVERS DEPT. FOR OTHER SPECIAL REQUIREMENTS

MULTI-SECTION ASSEMBLY

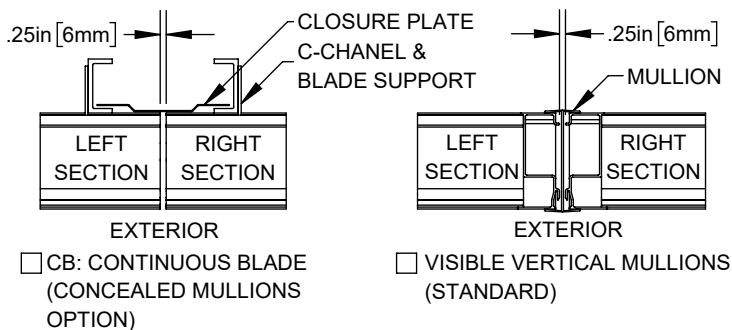

CHANNEL FRAME "A" MOUNTING SHOWN FOR OTHER MOUNTING METHODS SEE [274240](#)

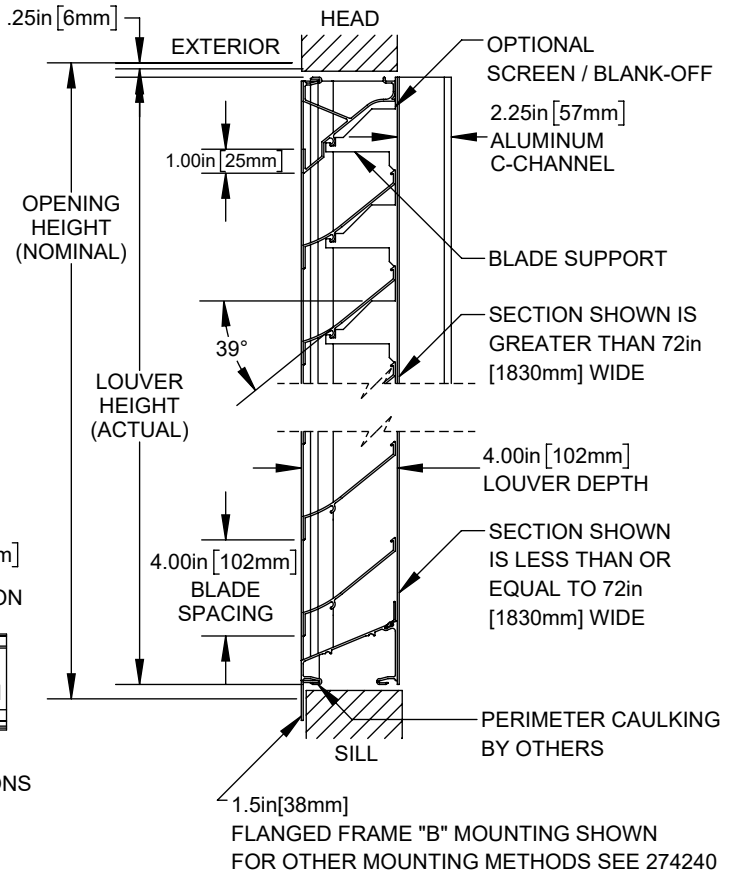

PROJECT:		PRICE [®]	
ENGINEER:			
CUSTOMER:		237945	
SUBMITTAL DATE:	SPEC. SYMBOL:	2025-07-18	