

MANUAL – INSTALLATION

Horizontal High Performance Fan Coils

FHP

v200 – Issue Date: 08/14/24

© 2024 Price Industries Limited. All rights reserved.

PRICE[®]

HORIZONTAL HIGH PERFORMANCE FAN COILS

TABLE OF CONTENTS

Product Overview

Safety Precautions.....	1
Caution to Contractors	2
Caution to Users.....	2
Receiving Inspection.....	2
Dimensional Data.....	3

Installation & Mounting Instructions

General.....	4
Electrical Connection	4
Cooling/Heating Pipe Connections	5
Mounting the Unit	5

Start Up & Operations

General.....	8
Cooling/Heating Pipe Connections	8
Air System Balancing.....	8
Water System Balancing.....	9

Maintenance

Safety.....	10
Fan and Motor.....	10
Coils and Drain Pan	10
Filter(s).....	11
Replacement Parts	11
Installation Checklist	17

HORIZONTAL HIGH PERFORMANCE FAN COILS

PRODUCT OVERVIEW

Safety Precautions

- A. **WARNING:** Installation work and electrical wiring must be done by qualified person(s) in accordance with all applicable codes and standards, including fire-rated construction.
- B. **WARNING:** When cutting or drilling into wall or ceiling, do not damage electrical wiring and other hidden utilities.
- C. **WARNING:** Protect flammable materials nearby when brazing, Use flame and heat protection barriers where needed. Always have a fire extinguisher ready.
- D. **WARNING:** Before servicing or cleaning unit, switch power off at service panel and lock service panel to prevent power from being switched on accidentally.
- E. **NOTE:** Maximum altitude for operating this product is 15,000 feet.
- F. The manufacturer assumes no responsibility for personal injury or property damage resulting from improper handling, installation, service or operation of the product.
- G. Use this unit only in the manner intended by the manufacturer. If you have any questions, contact the manufacturer:

In the United States

2975 Shawnee Ridge Court Suwanee, Georgia USA 30024 Ph: 770.623.8050 Fax: 770.623.6404

In Canada or International Export Sales Office

638 Raleigh Street Winnipeg, Manitoba Canada R2K 3Z9 Ph: 204.669.4220 Fax: 204.663.2715

HORIZONTAL HIGH PERFORMANCE FAN COILS

PRODUCT OVERVIEW

Caution to Contractors

Fan Coil units are not intended for use as temporary heat or ventilation sources during building construction. The coil units are not designed nor equipped to operate in a dusty construction environment. Recirculating fan wheels can become coated in construction dust, resulting in an unbalanced wheel. This in turn can contribute to reduced motor life. Inlet air filters, if supplied, would provide little protection as they would quickly become plugged with construction dust.

FHPP PLENUM CONFIGURATION ▼

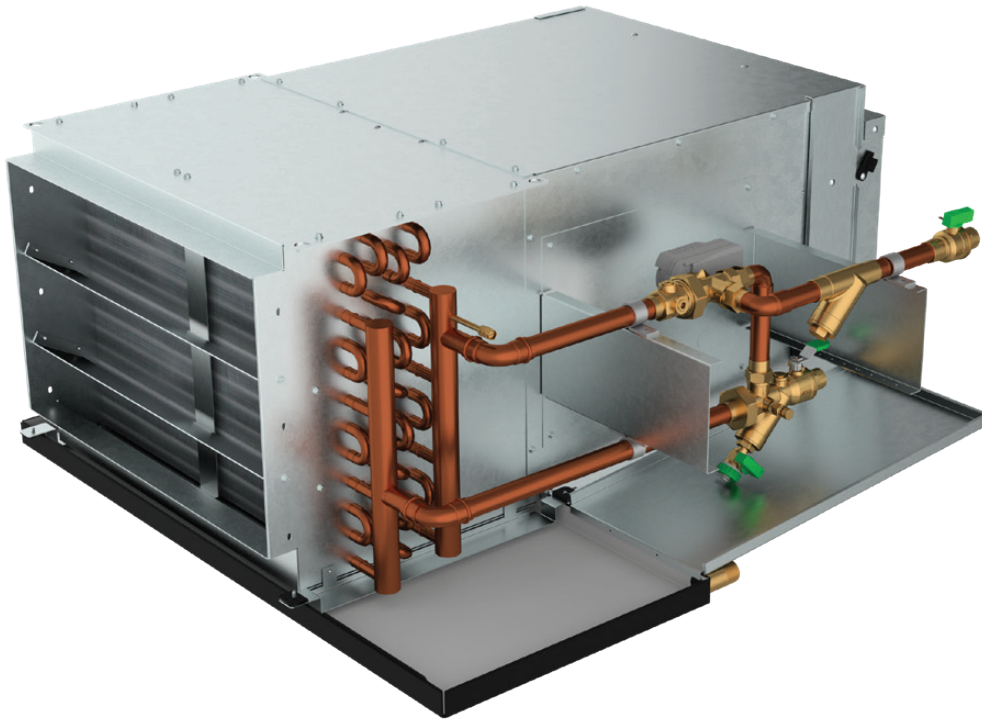

Caution to Users

This product is not intended for use by persons (including children) with reduced physical, sensory or mental capabilities, or lack of experience and knowledge, unless they have been given supervision or instruction concerning use of the product by a person responsible for their safety. Children should be supervised to ensure that they do not play with the product.

Receiving Inspection

All Price Fan Coil units are inspected before shipment. After unpacking the assembly, check it for damage. If any damage to the products is found, report it immediately to the delivery carrier. Ensure that all packing material is removed from the inside of the unit, especially around the blower wheel and coil section.

HORIZONTAL HIGH PERFORMANCE FAN COILS

PRODUCT OVERVIEW

DIMENSIONAL DATA - FHPE ▼

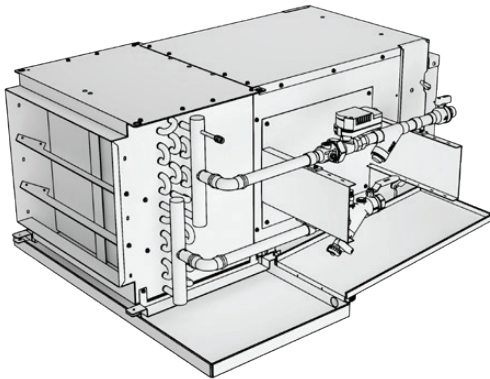

FHPP

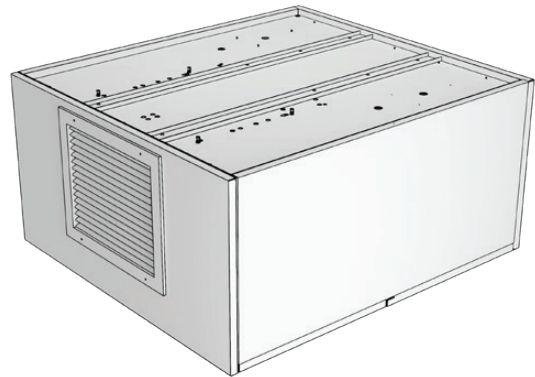

FHPE

Model	Size	Width (W)	Height (H)	Length (L)	
				Cooling or Heating Only	Preheat or Reheat
FHPP (Rear Return)	06	16 in. (406 mm)	14 ¼ in. (362 mm)	33 5/8 in. (855 mm)	38 5/8 in. (981 mm)
	08	20 in. (508 mm)			
	10	24 in. (610 mm)			
	12	32 in. (813 mm)			
	16	40 in. (1016 mm)	18 ½ in. (470 mm)		
	18	32 in. (813 mm)			
	20	48 in. (1219 mm)			
	26	48 in. (1219 mm)			
FHPP (Bottom Return)	06	16 in. (406 mm)	19 7/8 in. (505 mm)	32 ¼ in. (819 mm)	37 ¼ in. (946 mm)
	08	20 in. (508 mm)			
	10	24 in. (610 mm)			
	12	32 in. (813 mm)			
	16	40 in. (1016 mm)	24 7/8 in. (632 mm)		
	18	32 in. (813 mm)			
	20	48 in. (1219 mm)			
	26	48 in. (1219 mm)			
FHPE	06	38 in. (965 mm)	20 ¼ in. (514 mm)	42 1/8 in. (1070 mm)	
	08	42 in. (1067 mm)			
	10	46 in. (1168 mm)			
	12	54 in. (1372 mm)			
	16	62 in. (1575 mm)	25 ¼ in. (641 mm)		
	18	54 in. (1372 mm)			
	20	70 in. (1778 mm)			
	26	70 in. (1778 mm)			

Height is measured from the top of the unit to the lowest point of the drain pan.

HORIZONTAL HIGH PERFORMANCE FAN COILS

INSTALLATION & MOUNTING INSTRUCTIONS

General

Price Fan coils are designed to be durable and manufactured for sturdy construction. The units must still be handled with great care and no force or pressure applied to the coil or piping. When handled, the unit should be carried in an upright position holding onto the mounting points on the horizontal units and holding onto the bottom of the vertical units. Do not handle the unit using coil stubout connectors, as damage may occur at brazed joint(s). The fan coils are not suitable for outdoor installations. The units should never be stored or installed where it may be subjected to a hostile environment such as rain, snow, or extreme temperatures. Care must be taken during and after installation to prevent foreign material such as paint, drywall mud or dust from entering the drain pan or the motor or blower wheels. Failure to do so may have serious effects on the unit performance and may cause premature failure if foreign material is allowed to be deposited into the motor or blower. Some job conditions may require the unit to be covered temporarily until installation.

WARNING: Do not tamper with control components.

Electrical Connection

WARNING: Disconnect all incoming power before any electrical installation or service is performed on the unit(s).

1. All field wiring is to be in accordance with the National Electrical Code ANSI/NFPA No. 70 or the Canadian Electrical Code, Part 1, CSA Standard C 22.1. Local codes and the National Electrical Code requirements take precedence over manufacturer recommendations, and adherence to these codes shall be the responsibility of the installing contractor.
2. Refer to the product identification label on each unit for information to determine the field wire size.
3. Check voltage requirements prior to power supply connection. Refer to the electrical label located on the electrical control box and also refer to the schematic drawing provided on the underside of the electrical control box cover. If an Electric Reheat Coil has been supplied, refer to the electrical schematic prior to hook-up.
4. If upon energizing the electric motor excessive noise is apparent, shut down the unit. Determine the cause by checking for packing materials, etc. and re-energize after corrective action has been taken.
5. Unit grounding
 - i. This unit incorporates an earth connection for functional purposes only
6. Fuse Type and Rating:
 - i. Time-delay, 500VAC, 1/10 – 30A, 10kA I.R.
 - ii. Fuse size varies by unit size and configuration

Model	Size	Fuse Rating (A)				QTY	CCF
		Unit Voltage					
		115/1/60	208/1/60	240/1/60	277/1/60		
FHPP	06	8	4.5	4.5	4	1	2.5
	08	10	6	6	5	1	2.5
	10	12	6	6	6	1	2.5
	12	15	8	8	8	1	2.5
	16	10	6	6	5	2	2.5
	18	20	15	15	12	1	2.5
	20	10	6	6	6	2	2.5
	26	15	10	10	8	2	2.5
FHPE	06	10	6	6	5	1	2.5
	08	10	6	6	5	1	2.5
	10	12	6	6	6	1	2.5
	12	15	8	8	8	1	2.5
	16	10	6	6	5	2	2.5
	18	20	15	15	12	1	2.5
	20	12	7	7	6	2	2.5
	26	12	9	9	7	2	2.5

HORIZONTAL HIGH PERFORMANCE FAN COILS

INSTALLATION & MOUNTING INSTRUCTIONS

Cooling/Heating Pipe Connections

The piping must be installed in a counter flow configuration to achieve optimal performance. The water inlet should be located on the leaving air side of the coil and the outlet should be located on the entering air side of the coil as shown below.

The valve packages are easily damaged when introduced to excessive amounts of heat. Great caution must be made when the connections are made with “sweat” or solder joints. The valve must be in the open position during all soldering and brazing operations. Heat should be dissipated with a wet cloth wrapped around the valve body. Automatic valves must have the control cartridge removed for soldering.

WARNING: Max coil pressure = 300 psig (2068 kPa)

WARNING: Max coil temperature = 200 °F

WARNING: Max heating flow rate = 14 gpm

Mounting the Unit

COIL CONNECTION ORIENTATION ▼

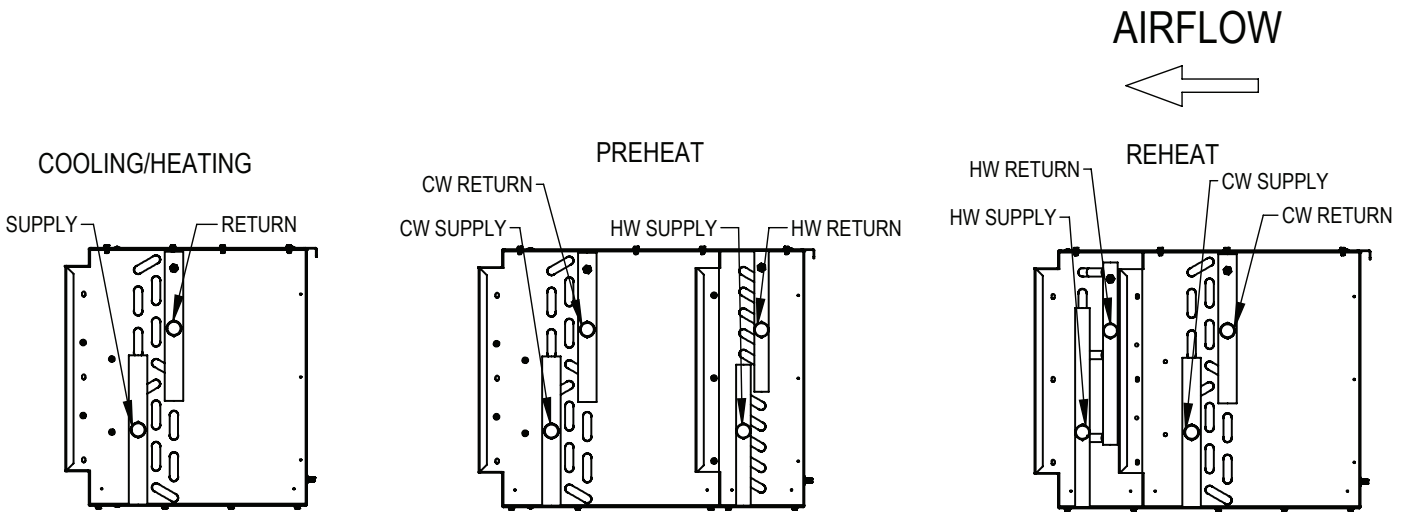

HORIZONTAL HIGH PERFORMANCE FAN COILS

INSTALLATION & MOUNTING INSTRUCTIONS

Install ductwork to comply with ASHRAE Fundamentals Handbook, local building codes and the National Electric Code.

Locate unit support in accordance with the mechanical and structural plans.

Hanging rods should be securely attached to joints or to mounting anchors which are properly secured to slab construction with lugs or poured in place anchors. All units are equipped with 5/8" knockouts in each corner of top and bottom panels for suspension rods to pass through as shown to the right.

Do not use Hanger brackets to install unit. Ensure the unit is installed so there is sufficient clearance for normal servicing. The drain pan is sloped toward the outlet connection when the unit is installed level and plumb. Ensure main power to the unit has been disconnected prior to performing any electrical work or inspection of the circuitry.

WARNING: Ensure that the mechanical fastener used on the hanger rod forms a lock so that it is incapable of vibrating loose. Serious injury and/or property damage may occur if the unit is not properly mounted.

HORIZONTAL HIGH PERFORMANCE FAN COILS

INSTALLATION & MOUNTING INSTRUCTIONS

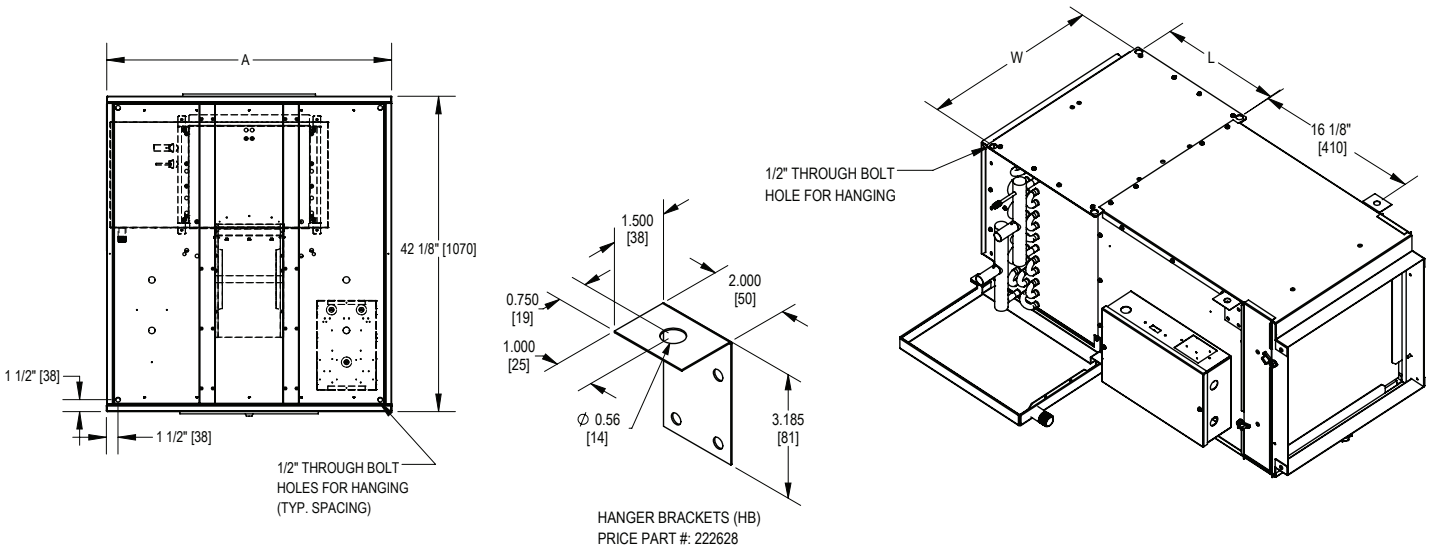

SPRING HANGER BRACKET (HBS) LOCATIONS

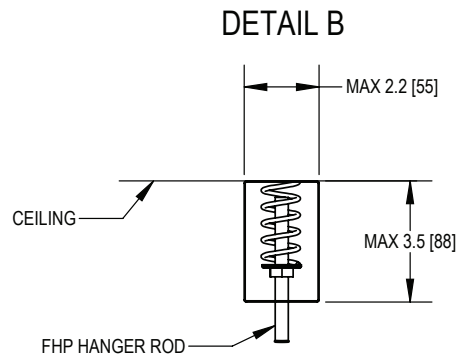
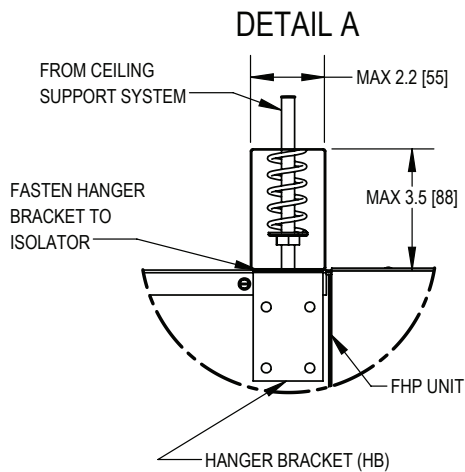
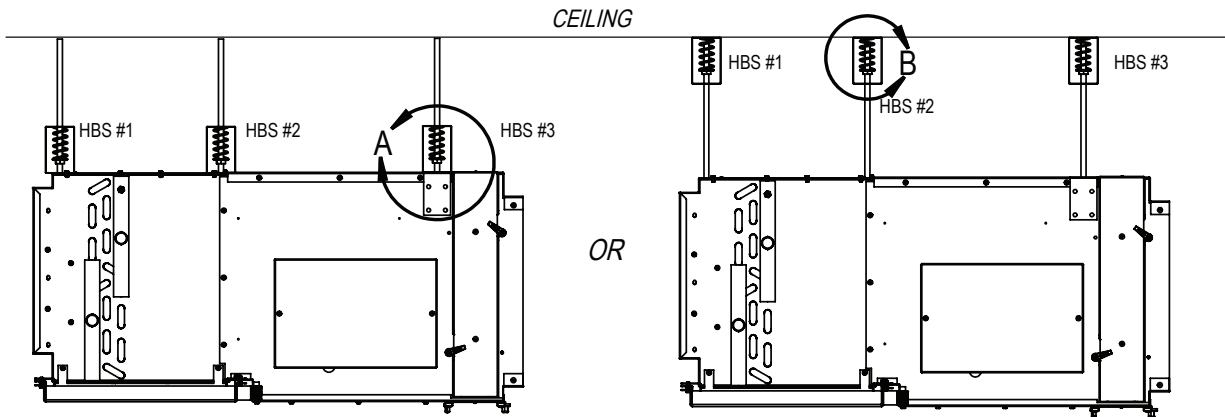

HORIZONTAL HIGH PERFORMANCE FAN COILS

INSTALLATION & MOUNTING INSTRUCTIONS

Start Up & Operation

General

Before beginning start up operation, familiarize yourself with the unit, options, accessories, controls so you understand proper system operation. All personnel should have a good working knowledge of general start-up procedures and have the appropriate start-up and balancing guides available for consultation.

Cooling/Heating

Prior to the water system start-up and balancing, the chilled/ hot water systems should be flushed to clean out dirt and debris, which may have collected in the piping during construction. During this procedure, all unit service valves must be in the closed position. This prevents foreign matter from entering the unit and clogging the valves and metering devices. Filters should be installed in the piping mains to prevent this material from entering the units during normal operation.

During system filling, air venting from the unit is accomplished by the use of the standard manual air vent fitting installed on the coil. The air vent screw should be turned counterclockwise no more than 1-½ turns to operate the air vent.

CAUTION: The air vent provided on the unit is not intended to replace the main system air vents and may not release air trapped in other parts of the system. Inspect the entire system for potential air traps and vent those areas as required, independently. In addition, some systems may require repeated venting over a period of time to properly eliminate air from the system..

Air System Balancing

NOTES: Prior to air system balancing, verify correct fan and motor rotation. This can be done by deenergizing the fan coil and observe the direction the fan wheel is rotating during coastdown. The fan wheel should rotate in the direction of the arrow that is either stamped on the fan housing (forward curve fan) or on a sticker located on the electric motor (plenum fan).

All duct-work must be complete and connected, and all grilles, filters, access doors and panels must be properly installed to establish actual system operating conditions BEFORE beginning air balancing operations. Each individual unit and attached duct-work is a unique system with its own operating characteristics. For this reason, air balancing is normally done by balance specialists who are familiar with all procedures required to properly establish air distribution and fan system operating conditions. These procedures should not be attempted by unqualified personnel. After the proper system operation is established, the actual unit air delivery and the actual fan motor amperage draw for each unit should be recorded in a convenient place for future reference.

The manufacturer assumes no responsibility for undesirable system operation due to improper design, equipment or component selection, and/or installation of ductwork, grilles, and other field supplied components.

HORIZONTAL HIGH PERFORMANCE FAN COILS

INSTALLATION & MOUNTING INSTRUCTIONS

FAN AND MOTOR ROTATION ▼



Water System Balancing

A complete knowledge of the hydronic system, its components, and controls is essential to proper water system balancing and this procedure should not be attempted by unqualified personnel. The system must be complete and all components must be in operating condition BEFORE beginning water system balancing operations. Each hydronic system has different operating characteristics depending on the devices and controls in the system. The actual balancing technique may vary from one system to another. After the proper system operation is established, the appropriate system operating conditions such as various water temperatures and flow rates should be recorded in a convenient place for future reference. Before and during water system balancing, conditions may exist which can result in noticeable water noise or undesired valve operation due to incorrect system pressures. After the entire system is balanced, these conditions will not exist on properly designed systems.

HORIZONTAL HIGH PERFORMANCE FAN COILS

MAINTENANCE

Safety

1. Periodic maintenance should be performed by a train professional.
2. Price Fan Coil units are supplied with permanently lubricated motors.

Fan and Motor

3. Disconnect all incoming power before servicing the unit.
4. Price Fan Coil units are supplied with permanently lubricated motors.
5. The blower and motor should be inspected annually for accumulation of dust and dirt. Clean as necessary.
6. Blower and motor can be accessed without disconnecting ductwork.

CAUTION: Motor may be very hot. Ensure motor has cooled before service.

Model	Size	EC Motor		Fans	Full Load Amps (A)			
		HP	Qty	Qty	115/1/60	208/1/60	240/1/60	277/1/60
FHPP	06	1/3	1	1	3.7	2.0	2.0	1.9
	08	1/3	1	1	5.0	2.8	2.8	2.6
	10	1/2	1	1	5.4	3.0	3.0	2.9
	12	1/2	1	1	6.6	3.7	3.7	3.5
	16	1/3	2	2	10.0	5.6	5.6	5.2
	18	3/4	1	1	9.6	6.8	6.8	5.5
	20	1/2	2	2	10.3	5.8	5.8	5.5
FHPE	26	3/4	2	2	13.6	9.6	9.6	7.8
	06	1/3	1	1	5.0	2.8	2.8	2.6
	08	1/3	1	1	5.0	2.8	2.8	2.6
	10	1/2	1	1	5.3	2.9	2.9	2.8
	12	1/2	1	1	6.9	3.9	3.9	3.7
	16	1/3	2	2	10.0	5.3	5.3	5.2
	18	3/4	1	1	9.6	6.8	6.8	5.5
FHPE	20	1/2	2	2	11.3	6.3	6.3	6.0
	26	3/4	2	2	12.2	8.7	8.7	7.0

NOTES:

- FLA for sizes 16, 20, and 26 include dual motors.
- Actual nameplate amps may vary but will not exceed values shown.
- ECM motors are impedance protected and provides the same protection as a thermal overload motor. This complies with VL 2111 overheating protection for motors.

Coils and Drain Pan

1. Disconnect all incoming power before servicing the unit.
2. To access coils for servicing, remove blower and motor assemblies.
3. The coil should be inspected periodically for accumulation of dust and dirt. Clean as necessary. Cleaning can be done by brushing the coils in the direction of the fins as to not damage them. Compressed air can also be used to blow out the dust particles in the coil. Vacuum up all dust particles so they can not damage the blower and motor.
4. Clean drain pan as required. To remove the drain pan, disconnect the drain.

HORIZONTAL HIGH PERFORMANCE FAN COILS

MAINTENANCE

Filter(s)

1. Inspect return air filters on a regular basis to avoid excessive restriction of air flow. Clean or replace filters as required. Filter can be accessed from either side of unit or from the bottom.

CAUTION: Do not operate unit without filters or filter access panels installed.

2. Replacement filter sizes are listed below.

Model	Size	Filters Specs		
		Height (in)	Width (in)	Quantity
FHPE	06	16	16	1
	08	16	20	1
	10	16	24	1
	12	16	16	2
	16	16	20	2
	18	16	16	2
	20	16	24	2
	26	16	24	2
FHPP	06	16	16	1
	08	16	20	1
	10	16	24	1
	12	16	16	2
	16	16	20	2
	18	16	20	2
	20	16	24	2
	26	20	24	2

Replacement Parts

Component		Part #	Description	Unit Size	
Filters	FHPP Plenum	MERV 8	275860-001	2" Merv 8 Filter - 16 x 16	06, 12
			275860-002	2" Merv 8 Filter - 16 x 20	08, 16, 18
			275860-003	2" Merv 8 Filter - 16 x 24	10, 20
			275860-004	2" Merv 8 Filter - 20 x 24	26
		MERV 13	275861-001	2" Merv 13 Filter - 16 x 16	06, 12
			275861-002	2" Merv 13 Filter - 16 x 20	08, 16, 18
			275861-003	2" Merv 13 Filter - 16 x 24	10, 20
			275861-004	2" Merv 13 Filter - 20 x 24	26
	FHPE Exposed	MERV 8	275860-001	2" Merv 8 Filter - 16 x 16	06, 12, 18
			275860-002	2" Merv 8 Filter - 16 x 20	08, 16
			275860-003	2" Merv 8 Filter - 16 x 24	10, 20, 26
		MERV 13	275861-001	2" Merv 13 Filter - 16 x 16	06, 12, 18
			275861-002	2" Merv 13 Filter - 16 x 20	08, 16
			275861-003	2" Merv 13 Filter - 16 x 24	10, 20, 26

HORIZONTAL HIGH PERFORMANCE FAN COILS

MAINTENANCE

Component	Part #	Description
1 Row Water Coil Left Hand	509377-102	FHP 06, 1 ROW, 2 CIR, LH
	509377-103	FHP 06, 1 ROW, 3 CIR, LH
	509377-202	FHP 08, 1 ROW, 2 CIR, LH
	509377-203	FHP 08, 1 ROW, 3 CIR, LH
	509377-302	FHP 10, 1 ROW, 2 CIR, LH
	509377-303	FHP 10, 1 ROW, 3 CIR, LH
	509377-402	FHP 12, 1 ROW, 2 CIR, LH
	509377-403	FHP 12, 1 ROW, 3 CIR, LH
	509377-502	FHP 16, 1 ROW, 2 CIR, LH
	509377-503	FHP 16, 1 ROW, 3 CIR, LH
	509377-602	FHP 18, 1 ROW, 2 CIR, LH
	509377-604	FHP 18, 1 ROW, 4 CIR, LH
	509377-702	FHP 20, 1 ROW, 2 CIR, LH
	509377-703	FHP 20, 1 ROW, 3 CIR, LH
	509377-802	FHP 26, 1 ROW, 2 CIR, LH
509377-804	FHP 26, 1 ROW, 4 CIR, LH	
1 Row Water Coil Right Hand	509383-102	FHP 06, 1 ROW, 2 CIR, RH
	509383-103	FHP 06, 1 ROW, 3 CIR, RH
	509383-202	FHP 08, 1 ROW, 2 CIR, RH
	509383-203	FHP 08, 1 ROW, 3 CIR, RH
	509383-302	FHP 10, 1 ROW, 2 CIR, RH
	509383-303	FHP 10, 1 ROW, 3 CIR, RH
	509383-402	FHP 12, 1 ROW, 2 CIR, RH
	509383-403	FHP 12, 1 ROW, 3 CIR, RH
	509383-502	FHP 16, 1 ROW, 2 CIR, RH
	509383-503	FHP 16, 1 ROW, 3 CIR, RH
	509383-602	FHP 18, 1 ROW, 2 CIR, RH
	509383-604	FHP 18, 1 ROW, 4 CIR, RH
	509383-702	FHP 20, 1 ROW, 2 CIR, RH
	509383-703	FHP 20, 1 ROW, 3 CIR, RH
	509383-802	FHP 26, 1 ROW, 2 CIR, RH
509383-804	FHP 26, 1 ROW, 4 CIR, RH	
2 Row Water Coil Left Hand	509378-102	FHP 06, 2 ROW, 2 CIR, LH
	509378-103	FHP 06, 2 ROW, 3 CIR, LH
	509378-202	FHP 08, 2 ROW, 2 CIR, LH
	509378-203	FHP 08, 2 ROW, 3 CIR, LH
	509378-302	FHP 10, 2 ROW, 2 CIR, LH
	509378-303	FHP 10, 2 ROW, 3 CIR, LH
	509378-402	FHP 12, 2 ROW, 2 CIR, LH
	509378-403	FHP 12, 2 ROW, 3 CIR, LH
	509378-502	FHP 16, 2 ROW, 2 CIR, LH
	509378-503	FHP 16, 2 ROW, 3 CIR, LH
	509378-603	FHP 18, 2 ROW, 3 CIR, LH
	509378-605	FHP 18, 2 ROW, 5 CIR, LH
	509378-702	FHP 20, 2 ROW, 2 CIR, LH
	509378-703	FHP 20, 2 ROW, 3 CIR, LH
	509378-803	FHP 26, 2 ROW, 3 CIR, LH
509378-805	FHP 26, 2 ROW, 5 CIR, LH	

HORIZONTAL HIGH PERFORMANCE FAN COILS

MAINTENANCE

Component	Part #	Description
2 Row Water Coil Right Hand	509384-102	FHP 06, 2 ROW, 2 CIR, RH
	509384-103	FHP 06, 2 ROW, 3 CIR, RH
	509384-202	FHP 08, 2 ROW, 2 CIR, RH
	509384-203	FHP 08, 2 ROW, 3 CIR, RH
	509384-302	FHP 10, 2 ROW, 2 CIR, RH
	509384-303	FHP 10, 2 ROW, 3 CIR, RH
	509384-402	FHP 12, 2 ROW, 2 CIR, RH
	509384-403	FHP 12, 2 ROW, 3 CIR, RH
	509384-502	FHP 16, 2 ROW, 2 CIR, RH
	509384-503	FHP 16, 2 ROW, 3 CIR, RH
	509384-603	FHP 18, 2 ROW, 3 CIR, RH
	509384-605	FHP 18, 2 ROW, 5 CIR, RH
	509384-702	FHP 20, 2 ROW, 2 CIR, RH
	509384-703	FHP 20, 2 ROW, 3 CIR, RH
	509384-803	FHP 26, 2 ROW, 3 CIR, RH
509384-805	FHP 26, 2 ROW, 5 CIR, RH	
3 Row Water Coil Left Hand	509379-102	FHP 06, 3 ROW, 2 CIR, LH
	509379-104	FHP 06, 3 ROW, 4 CIR, LH
	509379-202	FHP 08, 3 ROW, 2 CIR, LH
	509379-204	FHP 08, 3 ROW, 4 CIR, LH
	509379-302	FHP 10, 3 ROW, 2 CIR, LH
	509379-304	FHP 10, 3 ROW, 4 CIR, LH
	509379-402	FHP 12, 3 ROW, 2 CIR, LH
	509379-404	FHP 12, 3 ROW, 4 CIR, LH
	509379-503	FHP 16, 3 ROW, 3 CIR, LH
	509379-504	FHP 16, 3 ROW, 4 CIR, LH
	509379-604	FHP 18, 3 ROW, 4 CIR, LH
	509379-606	FHP 18, 3 ROW, 6 CIR, LH
	509379-704	FHP 20, 3 ROW, 4 CIR, LH
	509379-706	FHP 20, 3 ROW, 6 CIR, LH
	509379-806	FHP 26, 3 ROW, 6 CIR, LH
509379-808	FHP 26, 3 ROW, 8 CIR, LH	
3 Row Water Coil Right Hand	509385-102	FHP 06, 3 ROW, 2 CIR, RH
	509385-104	FHP 06, 3 ROW, 4 CIR, RH
	509385-202	FHP 08, 3 ROW, 2 CIR, RH
	509385-204	FHP 08, 3 ROW, 4 CIR, RH
	509385-302	FHP 10, 3 ROW, 2 CIR, RH
	509385-304	FHP 10, 3 ROW, 4 CIR, RH
	509385-402	FHP 12, 3 ROW, 2 CIR, RH
	509385-404	FHP 12, 3 ROW, 4 CIR, RH
	509385-503	FHP 16, 3 ROW, 3 CIR, RH
	509385-504	FHP 16, 3 ROW, 4 CIR, RH
	509385-604	FHP 18, 3 ROW, 4 CIR, RH
	509385-606	FHP 18, 3 ROW, 6 CIR, RH
	509385-704	FHP 20, 3 ROW, 4 CIR, RH
	509385-706	FHP 20, 3 ROW, 6 CIR, RH
	509385-806	FHP 26, 3 ROW, 6 CIR, RH
509385-808	FHP 26, 3 ROW, 8 CIR, RH	

HORIZONTAL HIGH PERFORMANCE FAN COILS

MAINTENANCE

Component	Part #	Description
4 Row Water Coil Left Hand	509380-102	FHP 06, 4 ROW, 2 CIR, LH
	509380-104	FHP 06, 4 ROW, 4 CIR, LH
	509380-202	FHP 08, 4 ROW, 2 CIR, LH
	509380-204	FHP 08, 4 ROW, 4 CIR, LH
	509380-302	FHP 10, 4 ROW, 2 CIR, LH
	509380-304	FHP 10, 4 ROW, 4 CIR, LH
	509380-403	FHP 12, 4 ROW, 3 CIR, LH
	509380-406	FHP 12, 4 ROW, 6 CIR, LH
	509380-504	FHP 16, 4 ROW, 4 CIR, LH
	509380-508	FHP 16, 4 ROW, 8 CIR, LH
	509380-604	FHP 18, 4 ROW, 4 CIR, LH
	509380-608	FHP 18, 4 ROW, 8 CIR, LH
	509380-706	FHP 20, 4 ROW, 6 CIR, LH
	509380-708	FHP 20, 4 ROW, 8 CIR, LH
	509380-808	FHP 26, 4 ROW, 8 CIR, LH
4 Row Water Coil Right Hand	509386-102	FHP 06, 4 ROW, 2 CIR, RH
	509386-104	FHP 06, 4 ROW, 4 CIR, RH
	509386-202	FHP 08, 4 ROW, 2 CIR, RH
	509386-204	FHP 08, 4 ROW, 4 CIR, RH
	509386-302	FHP 10, 4 ROW, 2 CIR, RH
	509386-304	FHP 10, 4 ROW, 4 CIR, RH
	509386-403	FHP 12, 4 ROW, 3 CIR, RH
	509386-406	FHP 12, 4 ROW, 6 CIR, RH
	509386-504	FHP 16, 4 ROW, 4 CIR, RH
	509386-508	FHP 16, 4 ROW, 8 CIR, RH
	509386-604	FHP 18, 4 ROW, 4 CIR, RH
	509386-608	FHP 18, 4 ROW, 8 CIR, RH
	509386-706	FHP 20, 4 ROW, 6 CIR, RH
	509386-708	FHP 20, 4 ROW, 8 CIR, RH
	509386-808	FHP 26, 4 ROW, 8 CIR, RH
6 Row Water Coil Left Hand	509381-103	FHP 06, 6 ROW, 3 CIR, LH
	509381-104	FHP 06, 6 ROW, 4 CIR, LH
	509381-203	FHP 08, 6 ROW, 3 CIR, LH
	509381-204	FHP 08, 6 ROW, 4 CIR, LH
	509381-304	FHP 10, 6 ROW, 4 CIR, LH
	509381-306	FHP 10, 6 ROW, 6 CIR, LH
	509381-406	FHP 12, 6 ROW, 6 CIR, LH
	509381-409	FHP 12, 6 ROW, 9 CIR, LH
	509381-506	FHP 16, 6 ROW, 6 CIR, LH
	509381-509	FHP 16, 6 ROW, 9 CIR, LH
	509381-608	FHP 18, 6 ROW, 8 CIR, LH
	509381-612	FHP 18, 6 ROW, 12 CIR, LH
	509381-706	FHP 20, 6 ROW, 6 CIR, LH
	509381-709	FHP 20, 6 ROW, 9 CIR, LH
	509381-808	FHP 26, 6 ROW, 8 CIR, LH
509381-812	FHP 26, 6 ROW, 12 CIR, LH	

HORIZONTAL HIGH PERFORMANCE FAN COILS

MAINTENANCE

Component	Part #	Description
6 Row Water Coil Right Hand	509387-103	FHP 06, 6 ROW, 3 CIR, RH
	509387-104	FHP 06, 6 ROW, 4 CIR, RH
	509387-203	FHP 08, 6 ROW, 3 CIR, RH
	509387-204	FHP 08, 6 ROW, 4 CIR, RH
	509387-304	FHP 10, 6 ROW, 4 CIR, RH
	509387-306	FHP 10, 6 ROW, 6 CIR, RH
	509387-406	FHP 12, 6 ROW, 6 CIR, RH
	509387-409	FHP 12, 6 ROW, 9 CIR, RH
	509387-506	FHP 16, 6 ROW, 6 CIR, RH
	509387-509	FHP 16, 6 ROW, 9 CIR, RH
	509387-608	FHP 18, 6 ROW, 8 CIR, RH
	509387-612	FHP 18, 6 ROW, 12 CIR, RH
	509387-706	FHP 20, 6 ROW, 6 CIR, RH
	509387-709	FHP 20, 6 ROW, 9 CIR, RH
	509387-808	FHP 26, 6 ROW, 8 CIR, RH
8 Row Water Coil Left Hand	509382-103	FHP 06, 8 ROW, 3 CIR, LH
	509382-104	FHP 06, 8 ROW, 4 CIR, LH
	509382-204	FHP 08, 8 ROW, 4 CIR, LH
	509382-206	FHP 08, 8 ROW, 6 CIR, LH
	509382-306	FHP 10, 8 ROW, 6 CIR, LH
	509382-308	FHP 10, 8 ROW, 8 CIR, LH
	509382-406	FHP 12, 8 ROW, 6 CIR, LH
	509382-408	FHP 12, 8 ROW, 8 CIR, LH
	509382-506	FHP 16, 8 ROW, 6 CIR, LH
	509382-512	FHP 16, 8 ROW, 12 CIR, LH
	509382-608	FHP 18, 8 ROW, 8 CIR, LH
	509382-616	FHP 18, 8 ROW, 16 CIR, LH
	509382-706	FHP 20, 8 ROW, 6 CIR, LH
	509382-712	FHP 20, 8 ROW, 12 CIR, LH
	509382-808	FHP 26, 8 ROW, 8 CIR, LH
8 Row Water Coil Right Hand	509388-103	FHP 06, 8 ROW, 3 CIR, RH
	509388-104	FHP 06, 8 ROW, 4 CIR, RH
	509388-204	FHP 08, 8 ROW, 4 CIR, RH
	509388-206	FHP 08, 8 ROW, 6 CIR, RH
	509388-306	FHP 10, 8 ROW, 6 CIR, RH
	509388-308	FHP 10, 8 ROW, 8 CIR, RH
	509388-406	FHP 12, 8 ROW, 6 CIR, RH
	509388-408	FHP 12, 8 ROW, 8 CIR, RH
	509388-506	FHP 16, 8 ROW, 6 CIR, RH
	509388-512	FHP 16, 8 ROW, 12 CIR, RH
	509388-608	FHP 18, 8 ROW, 8 CIR, RH
	509388-616	FHP 18, 8 ROW, 16 CIR, RH
	509388-706	FHP 20, 8 ROW, 6 CIR, RH
	509388-712	FHP 20, 8 ROW, 12 CIR, RH
	509388-808	FHP 26, 8 ROW, 8 CIR, RH
509388-816	FHP 26, 8 ROW, 16 CIR, RH	

HORIZONTAL HIGH PERFORMANCE FAN COILS

MAINTENANCE

Component	Part #	Description	Unit Size
Motors (ECM)	019179-002	1/3 HP Motor	FHP 06, 08, 16
	019179-001	1/2 HP Motor	FHP 10, 12, 20
	019179-003	3/4 HP Motor	FHP 18, 26
Motor Mounts	019732-001	Belly Band, 3 Leg, 120 deg	FHP 06, 08, 10, 12, 16, 20
	019734-002	Belly Band, 4 Leg, 90 deg	FHP 18, 26
Blowers	100186-002	Blower	FHP 06, 08, 16
	100092-004	Blower	FHP 10, 12, 20
	100186-007	Blower	FHP 18, 26
Electrical Components	019186-001	ECM Cable, 2 ft. (FHP 06, 08, 10)	FHP 06, 08, 10
	019186-002	ECM Cable, 6 ft. (FHP 12, 16, 18, 20, 26)	FHP 12, 16, 18, 20, 26
	232953-100	ECM Speed Controller	All Sizes
	019187-001	115 V Power Cable, 6 ft.	All Sizes
	019187-002	208-240 V, 277V Power Cable, 6 ft.	All Sizes
	019903-001	115 V / 277 V Single Pole	All Sizes
	019903-003	208 V / 240 V Double Pole	All Sizes
	019459-001	Fuse Block 600V 30A	All Sizes
	019124-005	Fuse, 500V, 2.5A	All Sizes
	019064-013	Low Voltage Terminal Block	All Sizes
	019949-002	High Voltage Terminal Block	All Sizes
	019436-009	24/24V Transformer	All Sizes
	019436-001	115/24V Transformer	All Sizes
	019436-011	208-240/24V Transformer	All Sizes
	019439-001	277/24V Transformer	All Sizes

HORIZONTAL HIGH PERFORMANCE FAN COILS

MAINTENANCE

Installation Checklist

Receiving & Inspection

- Receiving & inspection
- Unit received undamaged
- All parts accounted for
- Unit arrangement/hand correct

Handling and Installation

- Unit mounted level and plumb
- Correct electrical service
- Proper access available for unit and components
- Correct overcurrent protection provided
- Correct service switch/disconnect provided
- Code compliance for all components
- Shipping screws and hardware removed
- Unit protected from dirt and foreign matter
- Set screws tightened

Cooling/Heating Connections

- Unit mounted level and plumb
- Proper access available for unit and components
- Correct chilled water line to the unit
- Correct hot water line to the unit
- Code compliance for all components
- Drain pan sloped properly

Ductwork Connections

- All ductwork, grilles, filters and access panels are installed
- Correct supply and return grille type and size
- Insulate ductwork as required
- Control outside air to protect from heat/cold

Electrical Connections

- Refer to unit wiring diagram
- Wiring in code compliance
- Connect power service

This document contains the most current product information as of this printing.
For the most up-to-date product information, please go to priceindustries.com.

© 2024 Price Industries Limited. All rights reserved.

