



Model FSD-AF-FA-211

U.L. 555S Classified
Leakage Class 1
Airfoil Blade

Front Access & Out of Wall/Partition Application

Combination Fire/Smoke Damper, U.L. 555 Classified 1 1/2 Hours

Model

Fire/Smoke Damper **FSD-AF-FA-211**

Standard Construction:

Frame: Roll-formed galvanized steel hat-section with staked corners with integral bracing.

Blades: Airfoil-shaped, double skin galvanized steel of roll-formed construction. Mechanically joined to form construction equivalent to 14 ga. steel. Minimum 5" (127mm) wide, Maximum 7" (178mm) wide.

Bearings: Bronze Oilite, press-fit into frame.

Axles: Square, plated steel.

Seals: High temperature inflatable silicone to 450°F. Air pressure assists sealing effects.

Linkage: Concealed in frame. Linkage bars are 12ga galvanized steel.

Sleeve: Galvanized, wrapped in thermal blanket (Typical 3 sides).

Heat Responsive Devices:
Fusible Links, 165° F and 212° F

Snap Disc, 250° F and 350° F

Finish: Mill galvanized.

Spring: Stainless steel.

Sizes: Minimum Size: 14"w x 10"h (356mm x 254mm)
Maximum Size: 42"w x 48"h (1067mm x 1219mm)

Notes: Dampers are furnished approximately 1/4" (6mm) smaller than given duct dimensions, (not including thermal blanket). Wall opening must be oversized by 3/8" (10mm) to accommodate thermal blanket thickness. Not recommended with blades running vertically.

Features

- The FSD-AF-FA-211 Combination Fire/Smoke Dampers have been designed and tested to exceed all U.L., U.L.C. and N.F.P.A. requirements for fire dampers as well as smoke dampers. They are intended for use where building codes call for the fire damper to also operate as a smoke damper.
- U.L. 555 and U.L.C. S112 listed and labelled as a 1 1/2 hour fire damper.

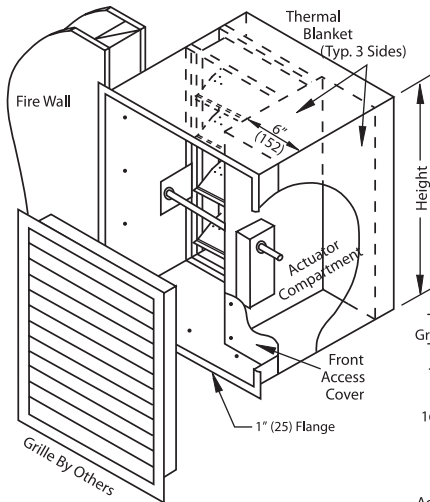

U.L. 555S CLASSIFIED
AT 250°F OR 350°F
DEPENDENT UPON
MOTOR/OPERATOR
*SEE MOTOR/OPERATOR SCHEDULE

LISTED AND LABELLED BY:

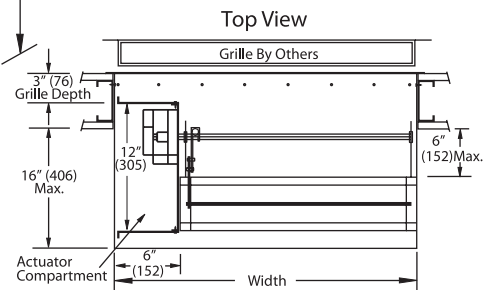

- U.L. and U.L.C. listed for vertical mounting.
- U.L. 555S and U.L.C. S112.1 listed and labelled as a Leakage Class I rated Smoke Damper with airflow in both directions. Class I provides for a maximum leakage of 8 cfm per sq. ft. at 4.0 inches static pressure. As we are constantly expanding our U.L./U.L.C. listings, we suggest you contact the factory for current information.
- Fusible link/actuator (DLT-1) provides an automatic override system to close and latch damper in the fire mode. **Also available with automatic resettable/override release options: Model STO/R (single thermostat) or Model DTO/R (double thermostat) to provide the fire fighter with complete discretionary control of smoke functions during a fire/smoke emergency. (See STO/R and DTO/R submittal drawings for complete details).** Spring return type damper motor controlled by a smoke detector is recommended to provide proper operation in the smoke mode.
- Also available are options EFL (Electric Fusible Link) and PFV (Pneumatic Fusible Valve). These options provide quick

and economical ways to check damper operations and also provide a Systematic Closure Control. Option PFV allows damper operation without the need/cost for an E-P valve and electrical connection at the damper.

Manufacturer's Recommendations

All moving parts of the damper must be inspected and cycled at intervals not greater than every six months and in accordance with the latest edition of NFPA 90A, 92A, local codes and the actuator manufacturer. In addition, fuse links shall be removed and inspected for corrosion. Dry lubricants are recommended.

Specifications are correct at time of printing. However, as part of our 'continuous improvement program,' we reserve the right to make further improvements without notice.

PROJECT:			
ENGINEER:			
CUSTOMER:		Oct / 12	
SUBMITTAL DATE:	SPEC. SYMBOL:	245067	

Model FSD-AF-FA-211



U.L. 555S Classified

Leakage Class 1

Airfoil Blade

Front Access & Out of Wall/Partition Application

Combination Fire/Smoke Damper, U.L. 555 Classified 1½ Hours

Pressure drop testing was done by an independent laboratory to AMCA Standard 500-D, Fig. 5.3 ductwork upstream & downstream.

DAMPER SIZE 36 x 36

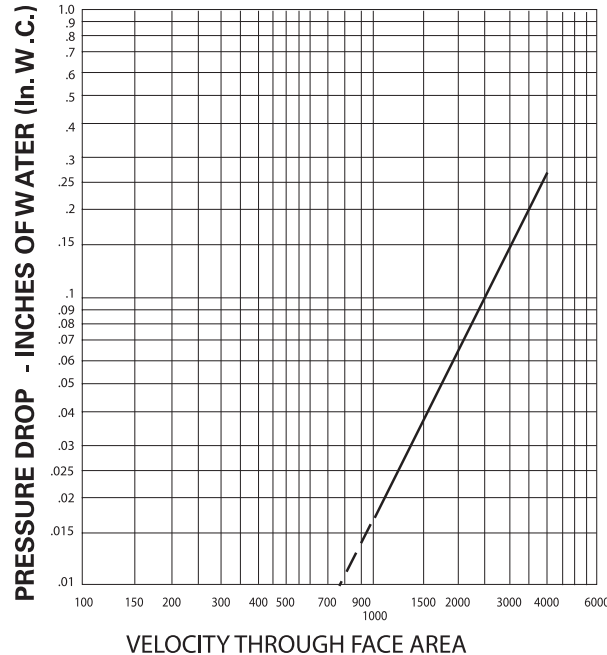

Note - performance data is for damper active area, and does not include actuator cabinet. To determine damper area, subtract 6" (152) from ordered width.

DAMPER SIZE 24 x 24

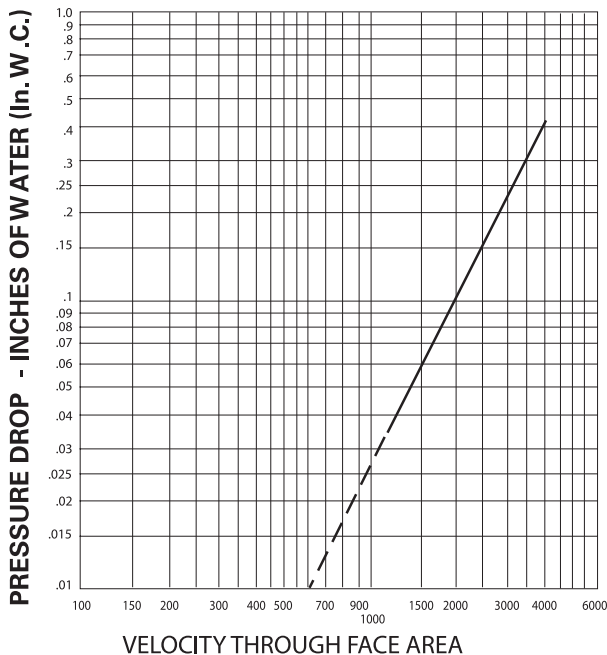

DAMPER SIZE 12 x 12

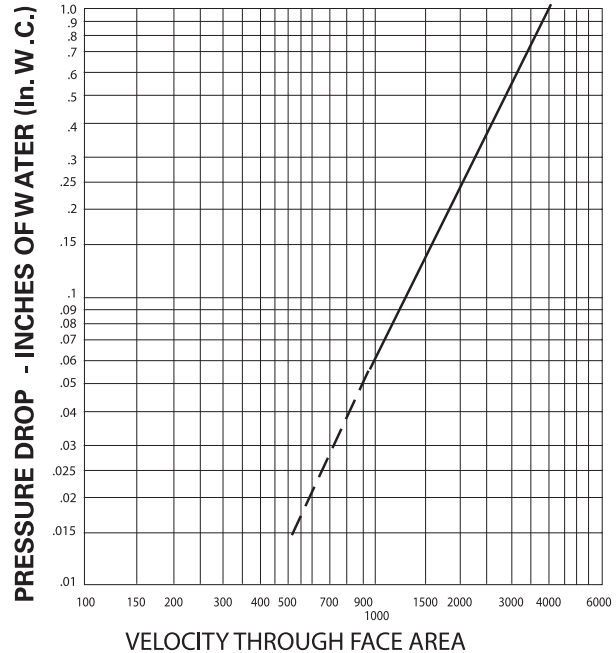



Model FSD-AF-FA-212

U.L. 555S Classified
Leakage Class 2
Airfoil Blade

Front Access & Out of Wall/Partition Application

Combination Fire/Smoke Damper, U.L. 555 Classified 1 1/2 Hours

Model

Fire/Smoke Damper **FSD-AF-FA-212**

Standard Construction:

Frame: Roll-formed galvanized steel hat-section with staked corners with integral bracing.

Blades: Airfoil-shaped, double skin galvanized steel of roll-formed construction. Mechanically joined to form construction equivalent to 14 ga. steel. Minimum 5" (127mm) wide, Maximum 7" (178mm) wide.

Bearings: Bronze Oilite, press-fit into frame.

Axles: Square, plated steel.

Seals: High temperature inflatable silicone to 450°F. Air pressure assists sealing effects.

Linkage: Concealed in frame. Linkage bars are 12ga galvanized steel.

Sleeve: Galvanized, wrapped in thermal blanket (Typical 3 sides).

Heat Responsive Devices:

Fusible Links, 165° F and 212° F

Snap Disc, 250° F and 350° F

Finish: Mill galvanized.

Spring: Stainless steel.

Sizes: Minimum Size: 14"w x 10"h (356mm x 254mm)

Maximum Size: 42"w x 48"h (1067mm x 1219mm)

Notes: Dampers are furnished approximately 1/4" (6mm) smaller than given duct dimensions, (not including thermal blanket). Wall opening must be oversized by 3/8" (10mm) to accommodate thermal blanket thickness. Not recommended with blades running vertically.

Features

- The FSD-AF-FA-212 Combination Fire/Smoke Dampers have been designed and tested to exceed all U.L., U.L.C. and N.F.P.A. requirements for fire dampers as well as smoke dampers. They are intended for use where building codes call for the fire damper to also operate as a smoke damper.
- U.L. 555 and U.L.C. S112 listed and labelled as a 1 1/2 hour fire damper.

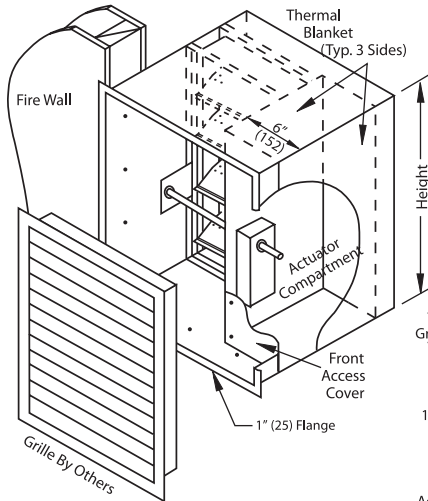

U.L. 555S CLASSIFIED AT 250°F OR 350°F DEPENDING UPON MOTOR/OPERATOR
*SEE MOTOR/OPERATOR SCHEDULE

LISTED AND LABELLED BY:

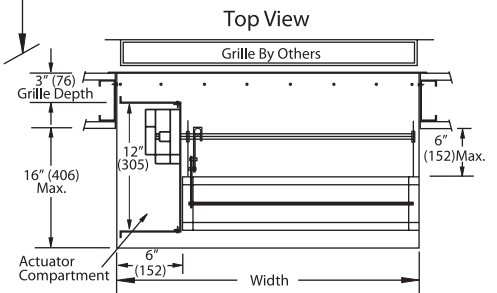

- U.L. and U.L.C. listed for vertical mounting.
- U.L. 555S and U.L.C. S112.1 listed and labelled as a Leakage Class II rated Smoke Damper with airflow in both directions. Class II provides for a maximum leakage of 20 cfm per sq. ft. at 4.0 inches static pressure. As we are constantly expanding our U.L./U.L.C. listings, we suggest you contact the factory for current information.
- Fusible link/actuator (DLT-1) provides an automatic override system to close and latch damper in the fire mode. **Also available with automatic resettable/override release options: Model STO/R (single thermostat) or Model DTO/R (double thermostat) to provide the fire fighter with complete discretionary control of smoke functions during a fire/smoke emergency. (See STO/R and DTO/R submittal drawings for complete details).** Spring return type damper motor controlled by a smoke detector is recommended to provide proper operation in the smoke mode.
- Also available are options EFL (Electric Fusible Link) and PFV (Pneumatic Fusible Valve). These options provide quick and economical ways to check damper operations and also provide a Systematic

Closure Control. Option PFV allows damper operation without the need/cost for an E-P valve and electrical connection at the damper.

Manufacturer's Recommendations

All moving parts of the damper must be inspected and cycled at intervals not greater than every six months and in accordance with the latest edition of NFPA 90A, 92A, local codes and the actuator manufacturer. In addition, fuse links shall be removed and inspected for corrosion. Dry lubricants are recommended.

Specifications are correct at time of printing. However, as part of our 'continuous improvement program,' we reserve the right to make further improvements without notice.

PROJECT:			
ENGINEER:			
CUSTOMER:		Oct / 12	
SUBMITTAL DATE:	SPEC. SYMBOL:	245068	

Model FSD-AF-FA-212



U.L. 555S Classified

Leakage Class 2

Airfoil Blade

Front Access & Out of Wall/Partition Application

Combination Fire/Smoke Damper, U.L. 555 Classified 1½ Hours

Pressure drop testing was done by an independent laboratory to AMCA Standard 500-D, Fig. 5.3 ductwork upstream & downstream.

DAMPER SIZE 36 x 36

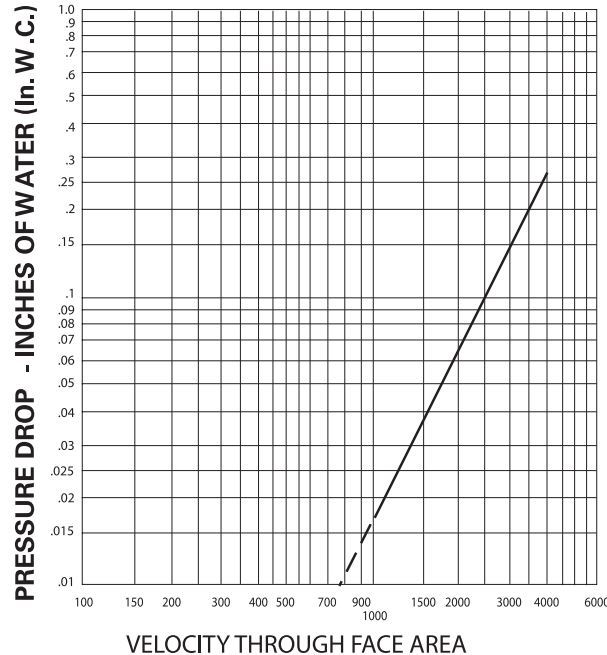

Note - performance data is for damper active area, and does not include actuator cabinet. To determine damper area, subtract 6" (152) from ordered width.

DAMPER SIZE 24 x 24

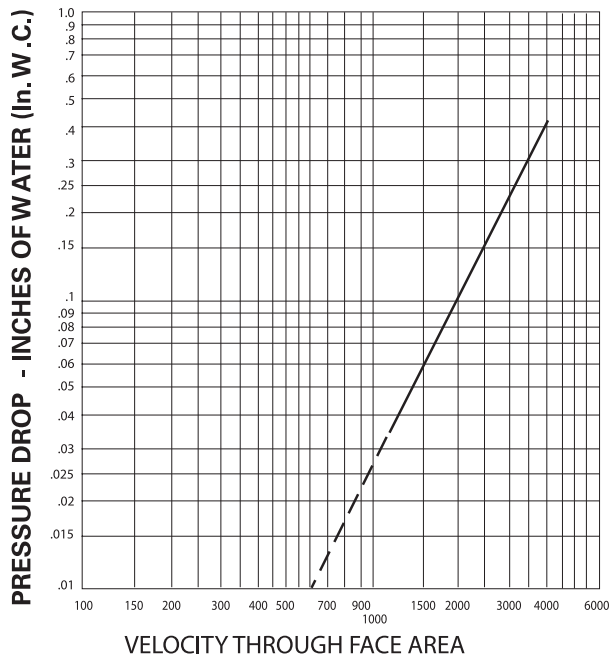

DAMPER SIZE 12 x 12

