

Dynamic Fire Damper, Horizontal and Vertical

Model

Dynamic Fire Damper **FDD-B-SL**

Standard Construction:

Frame: Roll Formed Galvanized Steel with Safety Edge.

Blades: Roll Formed Galvanized Steel, Curtain-Type

Springs: Stainless Steel.

Fusible Link: U.L. Listed 165°F.

1 1/2 & 3 Hr. Vertical:

Min. Size: 6"w X 4"h (152mm x 102mm)

Max. Single Sect.: 36"w X 32"h (914mm x 813mm)

Max. Size: 72"w X 32"h (1829mm x 813mm)

1 1/2 & 3 Hr. Horizontal:

Min. Size: 6"w X 4"h (152mm x 102mm)

Max. Single Sect.: 24"w X 21"h (610mm x 533mm)

Max. Size: 36"w X 32"h (914mm x 813mm)

Optional Construction:

- Factory Supplied Sleeve
 - 18 Gauge
 - 16 Gauge
 - 14 Gauge
 - 10 Gauge
 - Sleeve Length (Required) _____
- 3 Hour Rating
- 212°F fusible link (vertical only, 24"x21" (610mm x 533mm) max size)

Notes: Dampers are furnished approximately 1/4" (6mm) smaller than given duct dimensions.

UL/ULC Approved For Use in Dynamic and Static Systems.

Manufacturer's Recommendations

All moving parts of the damper must be inspected and cycled at intervals not greater than every six months and in accordance with the latest edition of NFPA 90A, 92A, local codes and the actuator manufacturer. In addition, fuse links shall be removed and inspected for corrosion. Dry lubricants are recommended.

Specifications are correct at time of printing. However, as part of our 'continuous improvement program,' we reserve the right to make further improvements without notice.

FDD-VB-SL

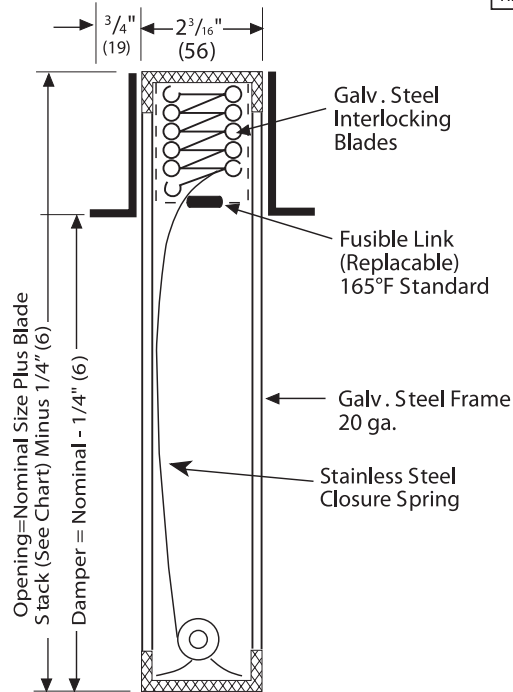

DESIGNED AND TESTED IN ACCORDANCE WITH UL-555 AND ULC-S112. MEETS ALL NFPA-90A REQUIREMENTS FOR FIRE DAMPERS.

LISTED AND LABELLED BY :



FDD-HB-SL

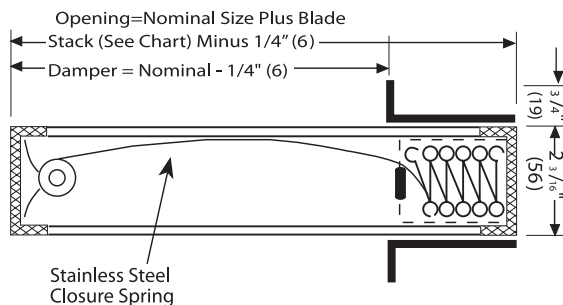

PROJECT:			
ENGINEER:			
CUSTOMER:			May / 08
SUBMITTAL DATE:	SPEC. SYMBOL:		245016

Model FDD-B-SL
 1½, 3 Hour Rated
 "B" Style

Dynamic Fire Damper, Horizontal and Vertical

TYPE B

W = Width (Duct)
 H = Height (Duct)
 $X = H + B$
 B = Blade Stack
 (see chart)

For dampers one section high:

Duct Height (H)	B
up to 20" (508)	2" (51)
21" (533) to 32" (813)	3" (76)

For HORIZONTAL dampers two sections high:

Duct Height (H)	B
up to 32" (813)	4" (102)

Note: See maximum section size for relevant hourly rating and mounting position to determine which chart to use.